

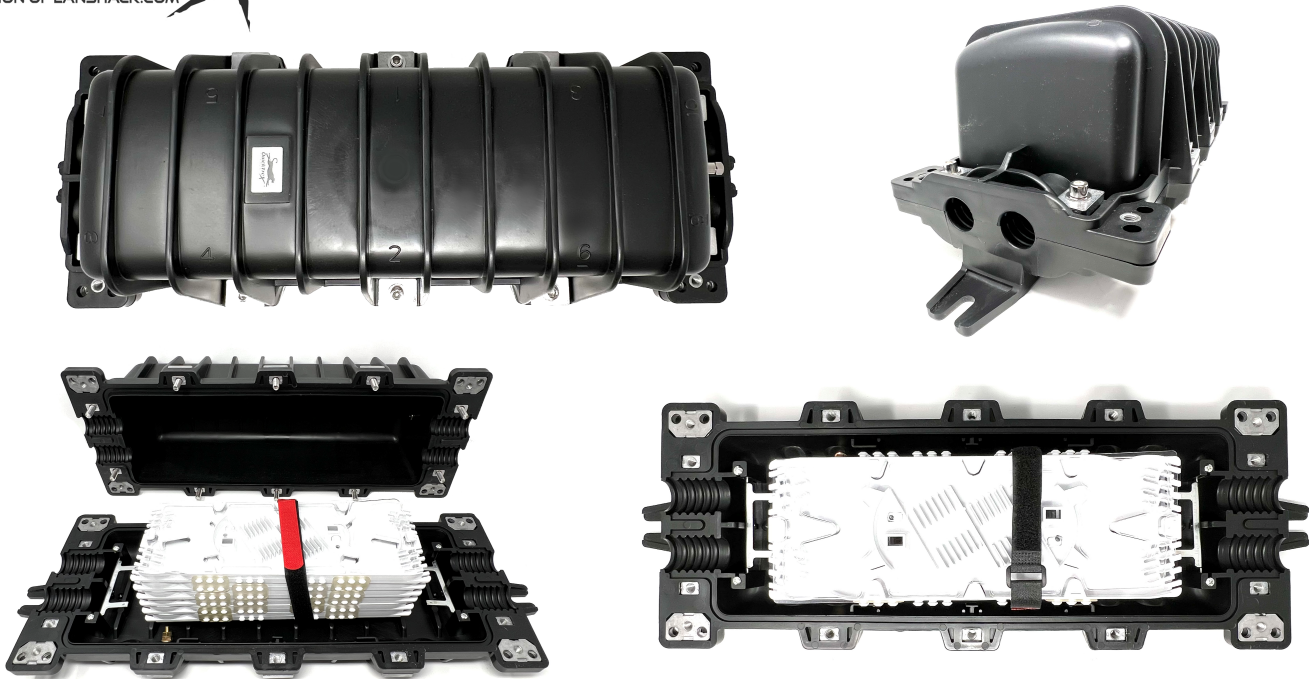

144 Fiber Outdoor IP68 Rated (Extra Depth) Aerial Horizontal / Wall Mount Fiber Optic Splice Enclosure with Splice Sleeves, Splice Trays, and Aerial Mounting Hardware

Part # QT-ED-AFOSE-144F-IP68



Overview

Our QuickTrex 144 Fiber Outdoor IP68 (Extra Depth) Rated Aerial Horizontal Fiber Optic Splice Enclosure is perfect for interconnectivity and termination of optical fibers in outdoor overhead distribution locations. Its made of high strength PC material to provide heavy duty UV and waterproof protection of your fiber optic connectors. It includes (6) 12/24 fiber hinged splice trays for high density and organized splicing. It offers a high quality sealing strip and heavy duty rubber gromets to help seal out moisture and dust. It's also lockable to prevent anyone from accessing the enclosure. This enclosure is designed to be aerially on a messenger wire. It includes aerial mounting brackets, plugs for unused cable entries, 144 splice sleeves, rubber tape, and zip ties.

SPECIFICATIONS

Dimensions: 18.11W" 7.48W x 4.52" D
Weight: 8 lbs
Fiber Capacity: 144 Fibers
Splice Trays: (6) 12/24 Fiber
Material: High Strength PC+PP Plastics
IP Rating: IP68
Color: Black
Cable Entry / Exit: 4
Work Temperature: 40 °C ~ +75 °C
Relative Humidity: ≤ 85%
Atmospheric Pressure: 70Kpa ~ 106Kpa
Standard: YC/T814.1-2004
Impact: 1m/1kg Steel Ball/ Three Times
Bending: 150N/±45°/10 cycles
Torsion: 50N.m/+90°/10 cycles
Insulation Resistance: 2x10⁴MΩ/500V
Compression Strength: 15kv/1min/10mA
ISO9001 Manufacturing

INCLUDES

Aerial Hanging Brackets
 (6) 12/24 Fiber Splice Trays
 144 Splice Sleeves
 Cable Entry Plugs
 Heavy Duty Sealing Strip
 Grounding Wires
 Zip Ties
 Rubber Tape
 Hex Key