

065-79XDMG Small Form-factor Pluggable (SFP) Gigabit Interface Module



The Signamax 065-79XDMG is a Small Form-factor Pluggable (SFP) multimode fiber module that supports Gigabit Ethernet over singlemode fiber cable at distances up to 40 kilometers. It adheres to the IEEE 802.3z standard for Gigabit Ethernet over singlemode fiber at 1550 nm, and is a cost-effective method of providing changeable Gigabit Ethernet singlemode interfaces to switches and media converters equipped with a standard SFP slot.

Applications

- Router / Server interface
- Distributed multi-processing
- Switch to switch interface
- High speed I/O for file server

Key Features

- Compliant with SFP MultiSource Agreement. Compliant with IEEE802.3z
- SCA-2 Host connector
- Duplex LC connector
- 1550 nm DFB Laser
- 3.3V power supply
- Hot-Pluggable capability
- Extended EMI & ESD protection
- Class 1 laser product complies with EN 60825-1

Ordering Information

Part Number	Description
065-79XDMG	1000BaseXD SFP Module 1550 nm – SM/LC, 40 km

Summary Specification

PART NUMBER	Model / Spectrum	Light Source	Link Power Budget	Typical Max. Distance**	Supply Voltage	Operating Temp.
065-79XDMG	XD 1550 nm	DFB Laser	18 dBm	40 km	3.3V	0 ~ 70 °C

** Maximum distances attainable on singlemode fiber circuits are dependent upon a circuit's conditions; i.e., the number of splices and patch panels and the number of bends in the circuit path. For comparison with competing products, please use the Link Power Budget for meaningful comparisons.

DETAILED SPECIFICATIONS

- **APPLICABLE STANDARDS**
 IEEE 802.3z (1000BaseXD Gigabit Ethernet)

- **ABSOLUTE MAXIMUM RATINGS**
Storage Temperature: TS -40 -- 85 °C
Supply Voltage: V_{CC} -0.5 -- 6.0 V
Input Voltage: V_{IN} -0.5 -- V_{CC} V
Operating Humidity: 5-95 %

- **RECOMMENDED OPERATING CONDITIONS**

PARAMETER	SYMBOL	MIN	MAX	UNITS	NOTE
Ambient Operating Temperature	T _{AMB}	0	70	°C	
Supply Voltage	V _{CC}	3.1	3.5	V	
Supply Current (3.3V)	I _{TX} + I _{RX}		85	mA	

- **TRANSMITTER ELECTRO-OPTICAL CHARACTERISTICS**

V_{CC} = 3.1 V to 3.5V, T_A = 0 °C to 70 °C

PARAMETER	SYMBOL	MIN	TYP.	MAX	UNITS	NOTE
Output Optical Power 9/125 μm fiber	P _{out}	-5	-2.5	0	dBm	Average
Extinction Ratio	ER	9			dB	
Center Wavelength	λ _C	1500	1550	1580	nm	
Spectral Width (20dB)	Δλ			1	nm	
Rise/Fall Time, (20–80%)	T _{r, f}			260	ps	
Side Mode Suppression Ratio	SMSR	30			dB	
Relative Intensity Noise	RIN			-120	dB/Hz	
Total Jitter	TJ			227	ps	
Output Eye	Compliant with IEEE802.3z					
Differential Data Input Swing	V _{IN}	200		1660	mV	
Transmit Fault Output-Low	TX_FAULT	0.0		0.5	V	
Transmit Fault Output-High	TX_FAULT	2.0		V _{CC}	V	

- **RECEIVER ELECTRO-OPTICAL CHARACTERISTICS**

V_{CC} = 3.1 V to 3.5 V, T_A = 0 °C to 70 °C

PARAMETER	SYMBOL	MIN	TYP.	MAX	UNITS	NOTE
Optical Input Power-maximum	P _{IN}	-3			dBm	BER < 10 ⁻¹²
Optical Input Power-minimum (Sensitivity)	P _{IN}		-26	-23	dBm	BER < 10 ⁻¹²
Operating Center Wavelength	λ _C	1260		1610	nm	
Receiver Electrical 3dB Upper Cutoff Frequency				1500	MHz	
Loss of signal –Asserted	P _A	-35			dBm	
Loss of signal –Deasserted	P _D			-23	dBm	
Differential Data Output Swing	V _{out}	370		2000	MV	
Receiver Loss of Signal Output Voltage-Low	RX_LOS	0		0.5	V	
Receiver Loss of Signal Output Voltage-High	RX_LOS	2.0		V _{CC}	V	

DETAILED SPECIFICATIONS (continued)

• **TIMING REQUIREMENTS**

V_{cc} = 3.1 V to 3.5V, T_A = 0 °C to 70 °C

PARAMETER	SYMBOL	MIN	TYP.	MAX	UNITS	NOTE
TX_DISABLE Assert Time	t _{off}			10	µs	
TX_DISABLE Negate Time	t _{on}			1	ms	
Time to initialize, include reset of TX_FAULT	t _{init}			300	ms	
TX_FAULT from fault to assertion	t _{fault}			100	µs	
TX_DISABLE time to start reset	t _{reset}	10			µs	
Receiver Loss of Signal Assert Time (off to on)	t _{A,RX_LOS}			100	µs	
Receiver Loss of Signal Assert Time (on to off)	t _{D,RX_LOS}			100	µs	

• **DIMENSIONS (mm)**

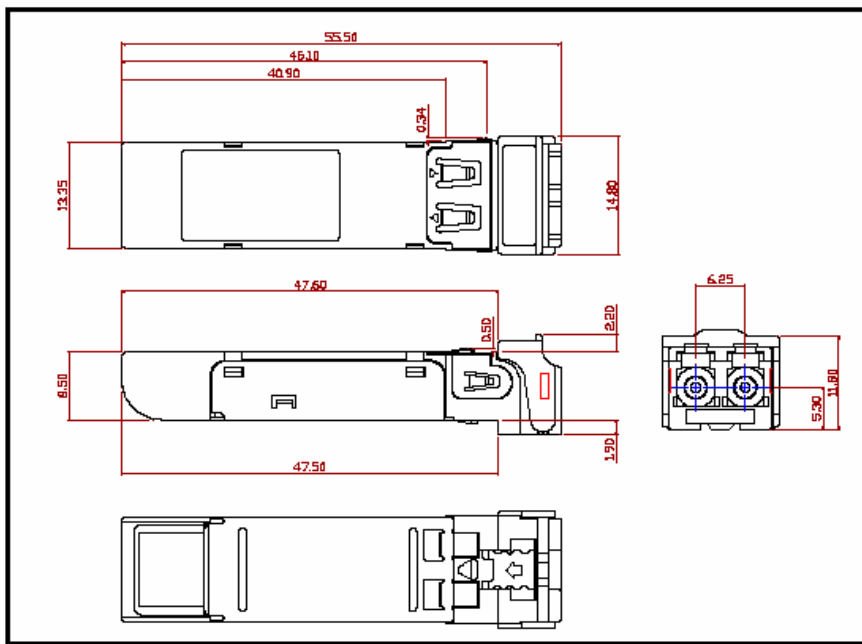

• **REGULATORY COMPLIANCE**

Feature	Test Method	Performance
Electrostatic Discharge (ESD) to optical connector	Variation of IEC 61000-4-2	Typically withstand at least 15kV without damage when port is contacted by Human Body Model probe.
Immunity	Variation of IEC 61000-4-3	Typically show no measurable effect from a 10 V/m field swept from 27 MHz to 1 GHz applied to the transceiver without a chassis enclosure.
Electromagnetic Interference (EMI)	FCC Class B CENELEC EN55022 Class B (CISPR 22A)	Margins are dependent on customer board and chassis design.
Laser Eye Safety	FDA21 CFR 1040.10 and 1040.11	Class 1 Laser Safety product.